

## Correct Use

The coded Magnetic switches are a series of technical safety devices for monitoring moveable separating safety guards. They ensure that dangerous works on machines can only be carried out if the safety guards are closed.

A stop command is triggered if a safety guard is opened while the machine is running. Before safety switches are used, a risk assessment must be performed on the machine in accordance with:

- EN ISO 13849-1:2008, Safety of machinery

Safety-related parts of control systems:

Part 1: General principles for design;

- EN ISO 14119:2013, interlocking devices associated with guards;

- EN 60204-1:2006, electrical equipment of machines;

- EN 60947-5-3:2013, Low-voltage switchgear and control gear.

Part 5-3: Control circuit devices and switching elements -

Requirements for proximity devices with defined behavior under fault conditions (PDDb).



## SAFETY PRECAUTIONS



Safe operation is ensured only when the complete system is used: sensor + coded magnet.

Safety sensors perform a personal protection function. Incorrect installation or handling, the use of spare magnets to activate sensors with open safety guards can lead to a serious injuries to people.

Coded switches must not be bypassed (bridging of contacts), turned away, removed or otherwise rendered ineffective. The switching operation may only be triggered by coded magnets specially provided for this purpose which are permanently connected to the safety guard.

A complete safety-oriented system generally consists of several signalling devices, sensors, control units and concepts for safe shut-off operations. The manufacturer of a machine or installation is responsible for correct and safe overall function.

## Operation

The safety system consists of a control unit, sensors and activation magnets and is only functional in particular position. The approach of the coded magnet to the sensor, respecting the alignment shown in Fig. 1, involves closing the solid-state safety outputs (pink-gray, black-white). The lighting up of the green LED indicates the correct alignment of the magnet and sensor and the relative activation of the safety outputs.

The red LED indicates instead the opening of the safety outputs. The safety status is defined as the state in which the sensor is far from its activation magnet (see "Circuit diagram").

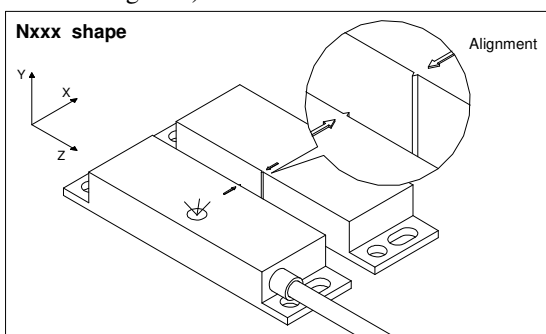

Fig. 1 Sensor alignment

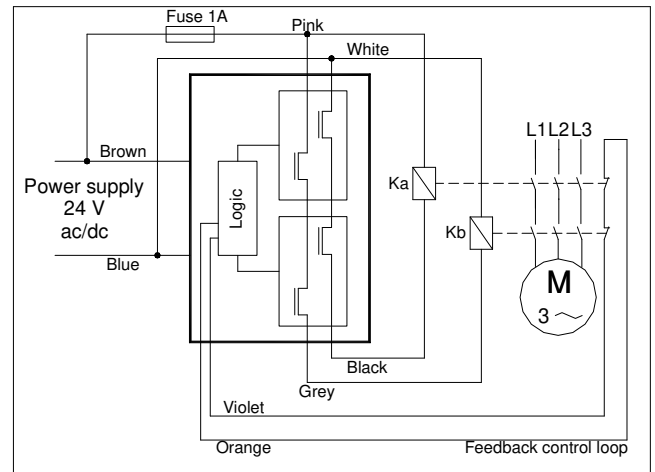

Fig. 2 Connections example for cat.3

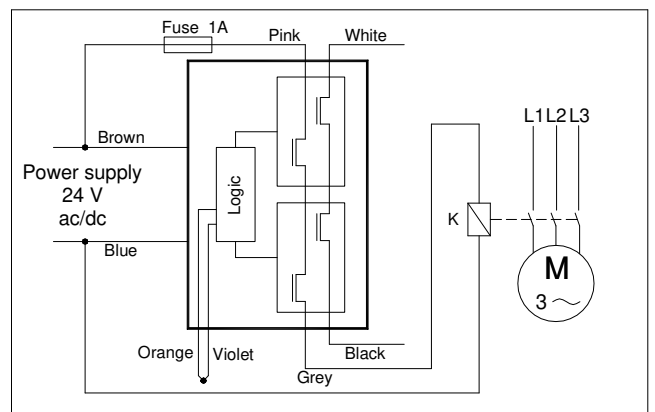

Fig. 3 Connections example for cat.1

## Installation

Installation must be performed by authorized personnel only. External 1A fast fuse is suggested on the safety line. Prevent the dismantling or de-positioning of the actuators (magnets) by use of non-detachable fixing (gluing, one-way screws).

Sensor and Magnets must not be used as a mechanical stop.

Sensor and Magnets must not be used in an environment with strong magnetic fields.

Sensor and Magnets must be positively locked to the safety guard.

Sensor and Magnets may be installed in any position.

The alignment of the Sensor and Magnets must be ensured.

Small misalignments are allowed to ensure correct operation even in the event of wear and tear that causes mechanical clearances.

Install Sensor and Magnets so that:

- They are accessible for inspection work and the installation of spare parts.
- When the safety guard is closed, the active read head and actuator area are exactly aligned (see "Sensors and Magnets alignment").
- The magnet is located in the sensor's response area when the safety guard is closed.
- A guide and an extra stop must be fitted to the moveable part of the safety guard.
- A stopping mechanism must be fitted to the protective doors for closed position.

- If the Sensor and Magnets are fitted flush, the switching distance is reduced depending on the installation depth and the safety guard material.
- If the Sensors and Magnets are fitted on ferromagnetic material, the activation distance is reduced.

**Service and inspection**

Remove iron swarf from the sensors and magnets at regular intervals. Only use solvent-free detergents for cleaning the magnets and sensors.

**Additional measures to minimize defeat possibilities (EN ISO 14119:2013, Table 3)**

It is mandatory to apply one of the following measures:

- 1) mounting sensors and magnets out of reach of the operator
- 2) physical obstruction or shielding of sensors and magnets
- 3) mounting sensors and magnets in hidden position
- 4) control periodically (at the beginning of every shift) the correct functioning of the sensors by checking:
  - correct switching function of each sensor:
    - a) the opening of the single sensor / safety guard will cause the opening of the safety outputs of the control unit.
    - b) the closure of the same sensor / safety guard will cause the closing of the safety outputs of the unit as a result of a startup command.
  - secure mounting of components
  - correct connection fixing.

If it were applied one of the points 1, 2, 3 you must still perform the check as described at point 4.

The monitoring function of the unit is done at every switching cycle.

If with all safety guards closed and following the eventual start command, the safety device does not activate its safety outputs, do not turn off and turn on the device, then proceed to the checking of the possible safety guard open and perform the above tests in point a) and b).

In the event of damage or wear and tear, the damaged system component must be replaced.

**Liability coverage is void under the following circumstances:**

- if instructions are not followed
- non-compliance with safety regulations
- installation and electrical connection not performed by authorized personnel
- non-implementation of functional checks.

DATI TECNICI	
Parameter	Value
Housing Material	glass-fiber reinforced PPS
Operational temperature	-25 ÷ +70°C
Protection degree (IEC 60529)	IP 67
Connection type	cable with terminals
Rated operational voltage	24VAC/VDC +/-15%
Maximum current	70mA
Rated imp. withstand voltage	1,5 kV
Pollution degree	3
Resettable fuse	0,1A PTC
External fuse on the safety line	1 A Fast
Activation distance S <sub>ao</sub> [mm]	<11
Reset distance S <sub>ar</sub> [mm]	>13
Repeat accuracy	<10%
Response time to off state [off]	<10ms
Safety outputs (pink white – gray - black)	AC1-AC15-DC13 VMAX 50 VDC /AC-picco I <sub>max</sub> =1A
Shock and vibration according to	EN 60947-5-3:2013
EMC according to	IEC 61326-3-1:2018
Max safety category (EN ISO 13849-1)	3
MTTFd	100 years
PL (EN ISO13849-1)	e (Cat.3): necessary monitoring of the status of the actuators by means of a feedback control loop (see Fig.2)  c (Cat.1)
TM	20 years
Safety norms compliance	EN ISO 13849-1:2015 EN ISO 14119:2013 (TYPE 4)
Approval	TUV IT 0948 19 MAC 0128 B

CONNECTIONS	
Color	Description
Brown	Power supply (V+ or L)
Blue	Power supply (GND or N)
Pink - Gray	1 <sup>a</sup> Safety output
Black -White	2 <sup>a</sup> Safety output
Violet - Orange	Feedback control loop
LED	
Color	Description
Green	Safety outputs activated
Red	Safety outputs deactivated

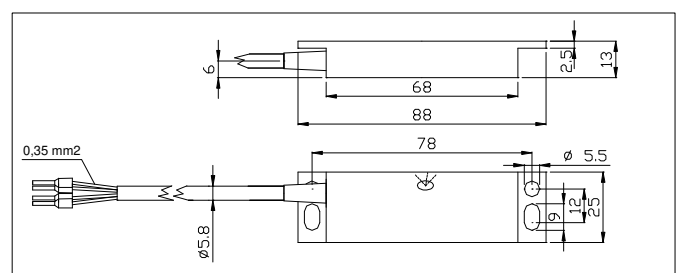

Fig. 4 Dimensions